

8 INCH WATER FILLED STANDARD MOTOR

Type	Pn [hp]	S.F	Un [Volts]	Thrust Load [N]	Full load Amps	RPM	Efficiency [%]	Cos ϕ [P.F]	TN [Nm]	Locked rotor Amps	[L] Length [in]	Gross weight [lbs.]
							F.L	F.L				
M8-0100-4604	10	1.15	460	45000	15.0	1746	80.46	0.782	41.0	4.50	36.5	321
M8-0100-5754	10	1.15	575	45000	11.8	1752	81.36	0.782	40.9	4.52	36.5	321
M8-0100-10004	10	1.15	1000	45000	6.7	1763	82.79	0.782	40.6	4.54	38.0	336
M8-0150-4604	15	1.15	460	45000	22.1	1739	81.30	0.785	60.4	4.52	36.5	336
M8-0150-5754	15	1.15	575	45000	17.3	1748	82.78	0.785	60.1	4.53	36.5	336
M8-0150-10004	15	1.15	1000	45000	10.0	1757	82.75	0.785	59.8	4.55	40.4	356
M8-0200-4604	20	1.15	460	45000	28.9	1744	83.09	0.790	82.2	4.54	40.4	356
M8-0200-5754	20	1.15	575	45000	22.7	1747	83.99	0.790	82.0	4.56	40.4	356
M8-0200-10004	20	1.15	1000	45000	13.2	1753	83.00	0.790	81.8	4.59	42.4	374
M8-0250-4604	25	1.15	460	45000	35.7	1744	83.31	0.793	101.3	4.55	42.4	374
M8-0250-5754	25	1.15	575	45000	28.0	1751	84.68	0.793	100.9	4.58	42.4	374
M8-0250-10004	25	1.15	1000	45000	16.3	1750	83.61	0.793	101.0	4.60	43.3	385
M8-0300-4604	30	1.15	460	45000	42.8	1740	83.22	0.797	120.8	4.56	43.3	385
M8-0300-5754	30	1.15	575	45000	33.5	1746	84.51	0.797	120.4	4.60	43.3	385
M8-0300-10004	30	1.15	1000	45000	19.4	1750	84.10	0.797	120.1	4.61	46.3	411
M8-0400-4604	40	1.15	460	45000	55.9	1740	84.57	0.800	164.7	4.58	46.3	411
M8-0400-5754	40	1.15	575	45000	44.6	1739	84.39	0.800	164.8	4.63	46.3	411
M8-0400-10004	40	1.15	1000	45000	25.5	1750	85.07	0.800	163.8	4.64	50.2	446
M8-0500-4604	50	1.15	460	45000	71.1	1726	82.78	0.820	204.8	4.59	50.2	446
M8-0500-5754	50	1.15	575	45000	54.1	1739	84.81	0.820	203.3	4.64	50.2	446
M8-0500-10004	50	1.15	1000	45000	31.3	1740	84.31	0.820	203.2	4.65	52.6	468
M8-0600-4604	60	1.15	460	45000	81.8	1729	84.20	0.835	248.7	4.61	52.6	468
M8-0600-5754	60	1.15	575	45000	63.5	1737	85.20	0.835	247.5	4.66	52.6	468
M8-0600-10004	60	1.15	1000	45000	36.5	1741	85.17	0.835	246.9	4.67	56.1	499
M8-0750-4604	75	1.15	460	45000	99.8	1729	84.38	0.840	303.9	4.62	56.1	499
M8-0750-5754	75	1.15	575	45000	78.6	1734	85.16	0.840	303.0	4.68	56.1	499
M8-0750-10004	75	1.15	1000	45000	44.8	1743	85.92	0.840	301.5	4.70	60.1	535

8 INCH WATER FILLED 316 STAINLESS STEEL MOTOR

Type	Pn [hp]	S.F	Un [Volts]	Thrust Load [N]	Full load Amps	RPM	Efficiency [%]	Cos φ [P.F]	TN [Nm]	Locked rotor Amps	[L] Length [in]	Gross weight [lbs.]
							F.L	F.L				
M8-0100-4604-316	10	1.15	460	45000	15.0	1746	80.46	0.782	41.0	4.50	36.5	331
M8-0100-5754-316	10	1.15	575	45000	11.8	1752	81.36	0.782	40.9	4.52	36.5	331
M8-0100-10004-316	10	1.15	1000	45000	6.7	1763	82.79	0.782	40.6	4.54	38.0	346
M8-0150-4604-316	15	1.15	460	45000	22.1	1739	81.30	0.785	60.4	4.52	36.5	346
M8-0150-5754-316	15	1.15	575	45000	17.3	1748	82.78	0.785	60.1	4.53	36.5	346
M8-0150-10004-316	15	1.15	1000	45000	10.0	1757	82.75	0.785	59.8	4.55	40.4	366
M8-0200-4604-316	20	1.15	460	45000	28.9	1744	83.09	0.790	82.2	4.54	40.4	366
M8-0200-5754-316	20	1.15	575	45000	22.7	1747	83.99	0.790	82.0	4.56	40.4	366
M8-0200-10004-316	20	1.15	1000	45000	13.2	1753	83.00	0.790	81.8	4.59	42.4	384
M8-0250-4604-316	25	1.15	460	45000	35.7	1744	83.31	0.793	101.3	4.55	42.4	384
M8-0250-5754-316	25	1.15	575	45000	28.0	1751	84.68	0.793	100.9	4.58	42.4	384
M8-0250-10004-316	25	1.15	1000	45000	16.3	1750	83.61	0.793	101.0	4.60	43.3	395
M8-0300-4604-316	30	1.15	460	45000	42.8	1740	83.22	0.797	120.8	4.56	43.3	395
M8-0300-5754-316	30	1.15	575	45000	33.5	1746	84.51	0.797	120.4	4.60	43.3	395
M8-0300-10004-316	30	1.15	1000	45000	19.4	1750	84.10	0.797	120.1	4.61	46.3	421
M8-0400-4604-316	40	1.15	460	45000	55.9	1740	84.57	0.800	164.7	4.58	46.3	421
M8-0400-5754-316	40	1.15	575	45000	44.6	1739	84.39	0.800	164.8	4.63	46.3	421
M8-0400-10004-316	40	1.15	1000	45000	25.5	1750	85.07	0.800	163.8	4.64	50.2	456
M8-0500-4604-316	50	1.15	460	45000	71.1	1726	82.78	0.820	204.8	4.59	50.2	456
M8-0500-5754-316	50	1.15	575	45000	54.1	1739	84.81	0.820	203.3	4.64	50.2	456
M8-0500-10004-316	50	1.15	1000	45000	31.3	1740	84.31	0.820	203.2	4.65	52.6	478
M8-0600-4604-316	60	1.15	460	45000	81.8	1729	84.20	0.835	248.7	4.61	52.6	478
M8-0600-5754-316	60	1.15	575	45000	63.5	1737	85.20	0.835	247.5	4.66	52.6	478
M8-0600-10004-316	60	1.15	1000	45000	36.5	1741	85.17	0.835	246.9	4.67	56.1	509
M8-0750-4604-316	75	1.15	460	45000	99.8	1729	84.38	0.840	303.9	4.62	56.1	509
M8-0750-5754-316	75	1.15	575	45000	78.6	1734	85.16	0.840	303.0	4.68	56.1	509
M8-0750-10004-316	75	1.15	1000	45000	44.8	1743	85.92	0.840	301.5	4.70	60.1	545

CABLE DATA

	8" WF STANDARD/8" WF 316SS
HP	10 - 75
ph	3
Type of start	DOL
Cable x Leads x Size [AWG]	1 x 4 x 6
Length [ft]	16.4
D [inch]	0.55 x 1.48
	

8" WF STANDARD

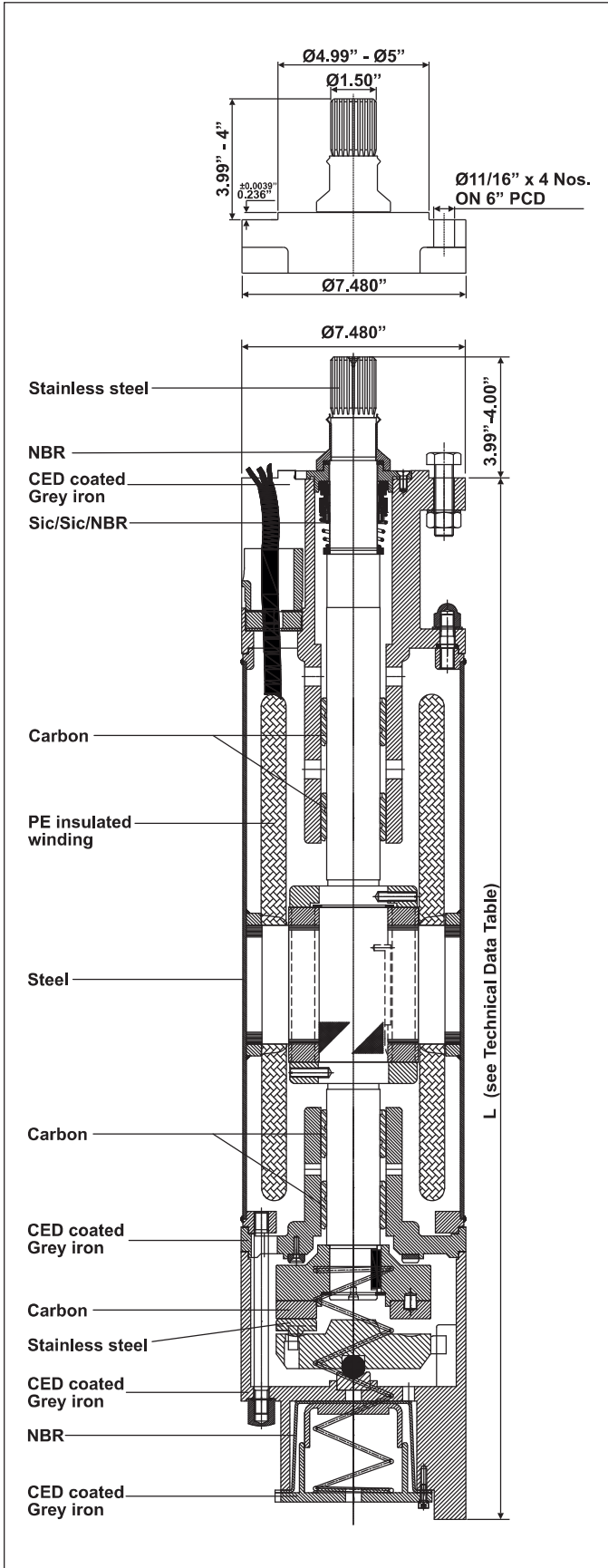

8" WF 316SS

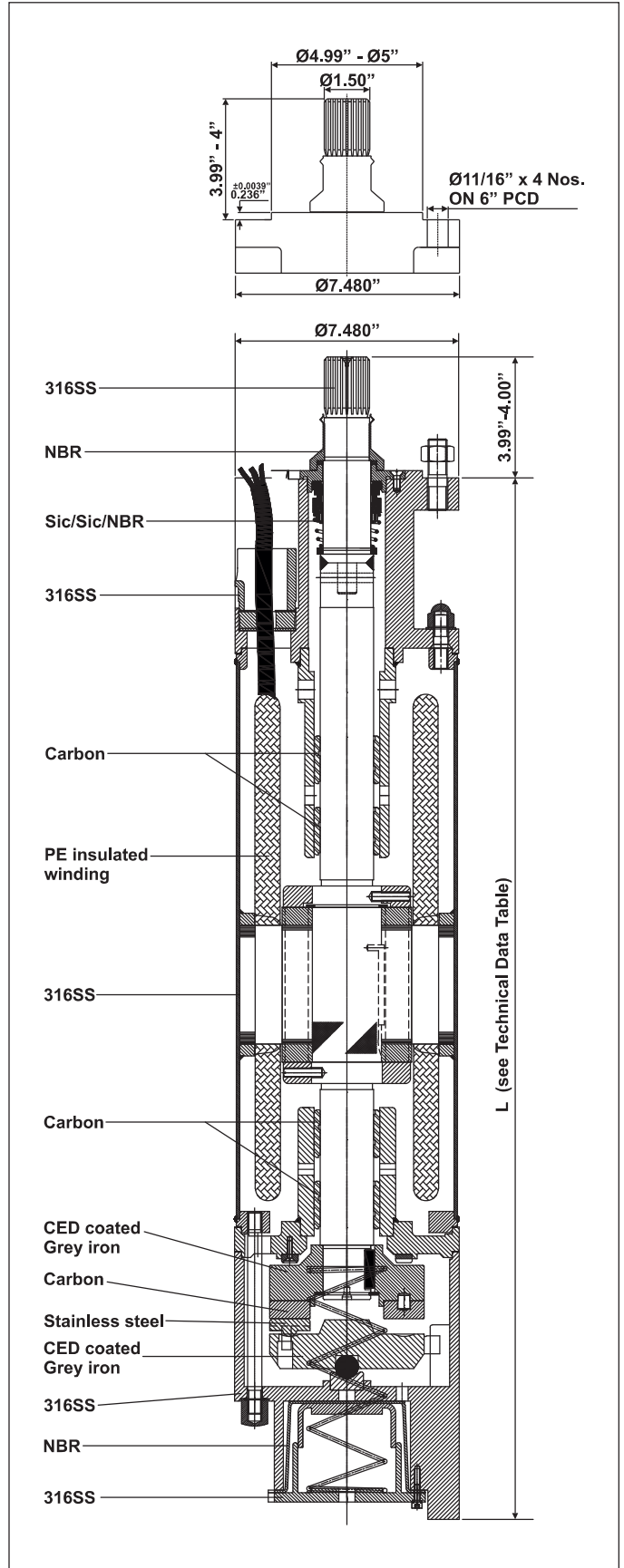



10 INCH WATER FILLED STANDARD MOTOR

Type	Pn [hp]	S.F	Un [Volts]	Thrust Load [N]	Full load Amps	RPM	Efficiency [%]	Cos ϕ [P.F]	TN [Nm]	Locked rotor Amps	[L] Length [in]	Gross weight [lbs.]
							F.L	F.L				
M10-0400-4604	40	1.15	460	60000	55.1	1759	85.45	0.800	162.9	4.52	50.3	608
M10-0400-5754	40	1.15	575	60000	43.5	1765	86.57	0.800	162.4	4.55	50.3	608
M10-0400-10004	40	1.15	1000	60000	25.1	1762	86.34	0.800	162.7	4.58	50.3	608
M10-0500-4604	50	1.15	460	60000	66.9	1758	86.29	0.815	201.1	4.54	52.6	650
M10-0500-5754	50	1.15	575	60000	53.5	1761	86.40	0.815	200.7	4.57	52.6	650
M10-0500-10004	50	1.15	1000	60000	30.8	1760	86.25	0.815	200.9	4.60	52.6	650
M10-0600-4604	60	1.15	460	60000	80.0	1753	86.15	0.820	245.3	4.55	53.4	666
M10-0600-5754	60	1.15	575	60000	63.0	1761	87.44	0.820	244.1	4.58	53.4	666
M10-0600-10004	60	1.15	1000	60000	36.5	1755	86.77	0.820	245.0	4.62	53.4	666
M10-0750-4604	75	1.15	460	60000	97.9	1757	86.94	0.826	299.1	4.57	57.0	723
M10-0750-5754	75	1.15	575	60000	77.9	1761	87.34	0.826	298.4	4.60	57.0	723
M10-0750-10004	75	1.15	1000	60000	45.1	1756	86.76	0.826	299.2	4.65	57.0	723
M10-1000-4604	100	1.15	460	60000	128.8	1751	86.98	0.840	409.2	4.59	61.7	796
M10-1000-5754	100	1.15	575	60000	102.7	1753	87.27	0.840	408.8	4.62	61.7	796
M10-1000-10004	100	1.15	1000	60000	59.4	1749	86.73	0.840	409.7	4.67	61.7	796
M10-1250-4604	125	1.15	460	60000	156.7	1757	87.67	0.854	505.7	4.60	66.0	875
M10-1250-5754	125	1.15	575	60000	125.5	1754	87.61	0.854	506.6	4.64	66.0	875
M10-1250-10004	125	1.15	1000	60000	71.8	1758	87.98	0.854	505.4	4.69	66.0	875
M10-1500-4604	150	1.15	460	60000	186.8	1754	87.53	0.860	599.2	4.62	71.5	968
M10-1500-5754	150	1.15	575	60000	149.0	1754	87.75	0.860	599.2	4.66	71.5	968
M10-1500-10004	150	1.15	1000	60000	85.9	1755	87.57	0.860	598.8	4.71	71.5	968
M10-1750-4604	175	1.15	460	60000	217.8	1755	87.58	0.862	707.7	4.65	78.6	1087
M10-1750-5754	175	1.15	575	60000	173.1	1758	88.16	0.862	706.5	4.69	78.6	1087
M10-1750-10004	175	1.15	1000	60000	100.0	1754	87.77	0.862	708.1	4.74	78.6	1087

10 INCH WATER FILLED 316 STAINLESS STEEL MOTOR

Type	Pn [hp]	S.F	Un [Volts]	Thrust Load [N]	Full load Amps	RPM	Efficiency [%]	Cos φ [P.F]	TN [Nm]	Locked rotor Amps	[L] Length [in]	Gross weight [lbs.]
							F.L	F.L				
M10-0400-4604-316	40	1.15	460	60000	55.1	1759	85.45	0.800	162.9	4.52	50.3	626
M10-0400-5754-316	40	1.15	575	60000	43.5	1765	86.57	0.800	162.4	4.55	50.3	626
M10-0400-10004-316	40	1.15	1000	60000	25.1	1762	86.34	0.800	162.7	4.58	50.3	626
M10-0500-4604-316	50	1.15	460	60000	66.9	1758	86.29	0.815	201.1	4.54	52.6	668
M10-0500-5754-316	50	1.15	575	60000	53.5	1761	86.40	0.815	200.7	4.57	52.6	668
M10-0500-10004-316	50	1.15	1000	60000	30.8	1760	86.25	0.815	200.9	4.60	52.6	668
M10-0600-4604-316	60	1.15	460	60000	80.0	1753	86.15	0.820	245.3	4.55	53.4	683
M10-0600-5754-316	60	1.15	575	60000	63.0	1761	87.44	0.820	244.1	4.58	53.4	683
M10-0600-10004-316	60	1.15	1000	60000	36.5	1755	86.77	0.820	245.0	4.62	53.4	683
M10-0750-4604-316	75	1.15	460	60000	97.9	1757	86.94	0.826	299.1	4.57	57.0	741
M10-0750-5754-316	75	1.15	575	60000	77.9	1761	87.34	0.826	298.4	4.60	57.0	741
M10-0750-10004-316	75	1.15	1000	60000	45.1	1756	86.76	0.826	299.2	4.65	57.0	741
M10-1000-4604-316	100	1.15	460	60000	128.8	1751	86.98	0.840	409.2	4.59	61.7	814
M10-1000-5754-316	100	1.15	575	60000	102.7	1753	87.27	0.840	408.8	4.62	61.7	814
M10-1000-10004-316	100	1.15	1000	60000	59.4	1749	86.73	0.840	409.7	4.67	61.7	814
M10-1250-4604-316	125	1.15	460	60000	156.7	1757	87.67	0.854	505.7	4.60	66.0	893
M10-1250-5754-316	125	1.15	575	60000	125.5	1754	87.61	0.854	506.6	4.64	66.0	893
M10-1250-10004-316	125	1.15	1000	60000	71.8	1758	87.98	0.854	505.4	4.69	66.0	893
M10-1500-4604-316	150	1.15	460	60000	186.8	1754	87.53	0.860	599.2	4.62	71.5	985
M10-1500-5754-316	150	1.15	575	60000	149.0	1754	87.75	0.860	599.2	4.66	71.5	985
M10-1500-10004-316	150	1.15	1000	60000	85.9	1755	87.57	0.860	598.8	4.71	71.5	985
M10-1750-4604-316	175	1.15	460	60000	217.8	1755	87.58	0.862	707.7	4.65	78.6	1105
M10-1750-5754-316	175	1.15	575	60000	173.1	1758	88.16	0.862	706.5	4.69	78.6	1105
M10-1750-10004-316	175	1.15	1000	60000	100.0	1754	87.77	0.862	708.1	4.74	78.6	1105

CABLE DATA

	10" WF STANDARD/10" WF 316SS	
HP	40 - 125	150 - 175
ph	3	3
Type of start	DOL	DOL
Cable x Leads x Size [AWG]	3 x 1 x 2 + 1 x 1 x 6	3 x 1 x 00 + 1 x 1 x 1
Length [ft]	16.4	16.4
D [inch]	0.55	0.55
		

10" WF STANDARD

10" WF 316SS

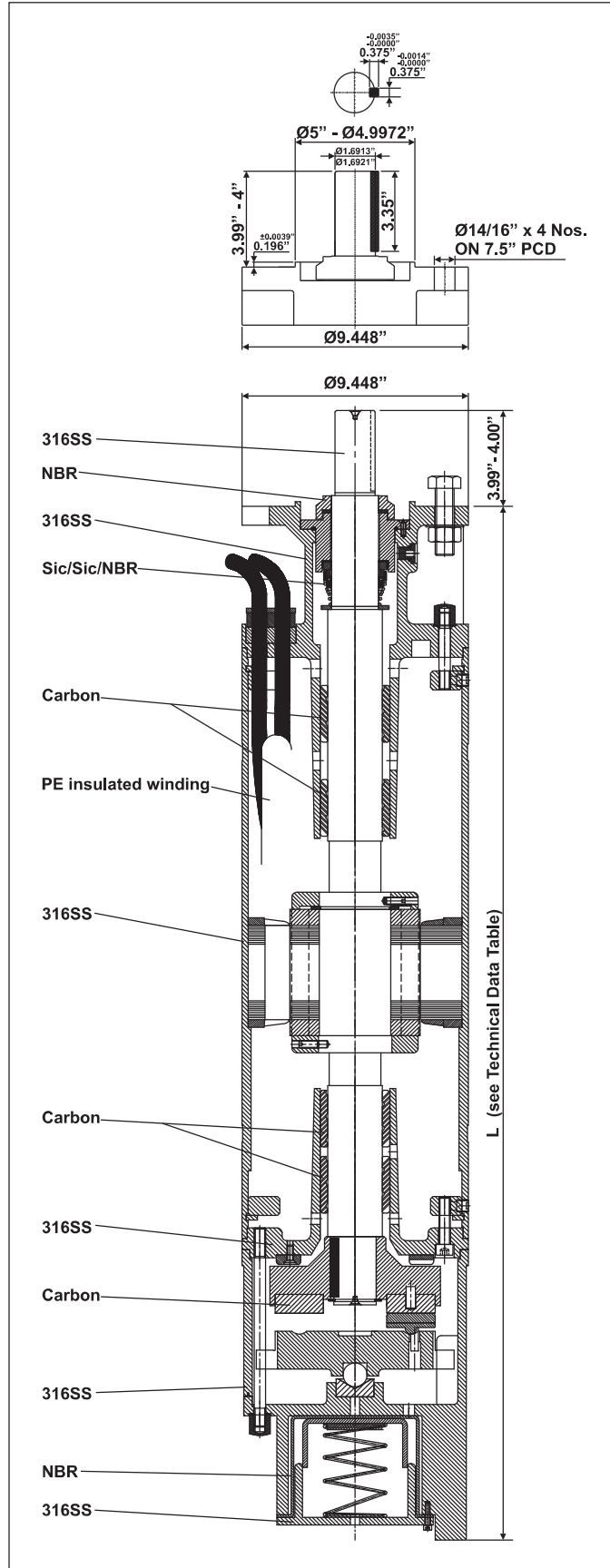
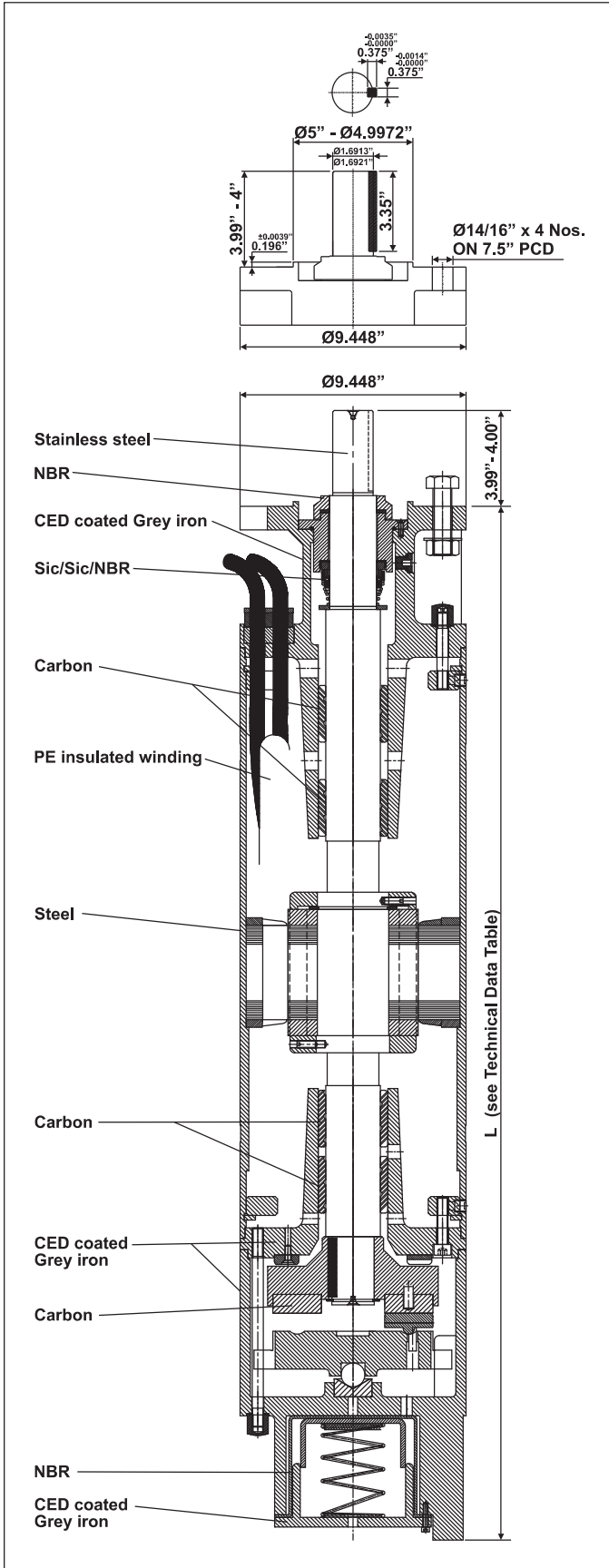

12 INCH WATER FILLED STANDARD MOTOR

Type	Pn [hp]	S.F	Un [Volts]	Thrust Load [N]	Full load Amps	RPM	Efficiency [%]	Cos φ [P.F]	TN [Nm]	Locked rotor Amps	[L] Length [in]	Gross weight [lbs.]
							F.L	F.L				
M12-1000-4604	100	1.15	460	70000	132.5	1760	87.49	0.812	407.1	4.50	51.4	785
M12-1000-5754	100	1.15	575	70000	104.9	1760	88.42	0.812	407.1	4.53	51.4	785
M12-1000-10004	100	1.15	1000	70000	59.4	1758	89.82	0.812	407.6	4.56	51.4	785
M12-1250-4604	125	1.15	460	70000	163.3	1760	87.87	0.818	504.8	4.55	54.1	908
M12-1250-5754	125	1.15	575	70000	129.0	1763	88.94	0.818	504.0	4.58	54.1	908
M12-1250-10004	125	1.15	1000	70000	73.2	1761	90.18	0.818	504.6	4.60	54.1	908
M12-1500-4604	150	1.15	460	70000	194.1	1762	88.33	0.820	596.4	4.57	57.3	1047
M12-1500-5754	150	1.15	575	70000	153.9	1762	89.11	0.820	596.4	4.62	57.3	1047
M12-1500-10004	150	1.15	1000	70000	87.1	1763	90.52	0.820	596.1	4.65	57.3	1047
M12-1750-4604	175	1.15	460	70000	227.2	1760	88.38	0.825	705.7	4.58	63.2	1228
M12-1750-5754	175	1.15	575	70000	180.1	1761	89.19	0.825	705.3	4.64	63.2	1228
M12-1750-10004	175	1.15	1000	70000	102	1762	90.53	0.825	704.9	4.67	63.2	1228
M12-2000-4604	200	1.15	460	70000	257.8	1760	87.99	0.830	814.3	4.60	67.1	1393
M12-2000-5754	200	1.15	575	70000	203.7	1763	89.07	0.830	812.9	4.64	67.1	1393
M12-2000-10004	200	1.15	1000	70000	115.5	1762	90.31	0.830	813.3	4.68	67.1	1393
M12-2250-4604	225	1.15	460	70000	288.3	1763	88.64	0.835	894.2	4.62	71.1	1442
M12-2250-5754	225	1.15	575	70000	228.5	1764	89.45	0.835	893.7	4.66	71.1	1442
M12-2250-10004	225	1.15	1000	70000	129.7	1763	90.64	0.835	894.2	4.70	71.1	1442
M12-2500-4604	250	1.15	460	70000	314.6	1760	88.30	0.845	1004.3	4.64	77.0	1671
M12-2500-5754	250	1.15	575	70000	248.3	1765	89.47	0.845	1001.4	4.67	77.0	1671
M12-2500-10004	250	1.15	1000	70000	141.4	1760	90.34	0.845	1004.3	4.71	77.0	1671
M12-2750-4604	275	1.15	460	70000	343.0	1761	88.78	0.845	1112.2	4.66	79.7	1777
M12-2750-5754	275	1.15	575	70000	271.3	1765	89.78	0.845	1109.7	4.69	79.7	1777
M12-2750-10004	275	1.15	1000	70000	154.7	1760	90.57	0.845	1112.8	4.72	79.7	1777
M12-3000-4604	300	1.15	460	70000	379.1	1762	88.68	0.840	1214.6	4.69	82.9	1898
M12-3000-5754	300	1.15	575	70000	300.1	1765	89.63	0.840	1212.5	4.73	82.9	1898
M12-3000-10004	300	1.15	1000	70000	170.8	1761	90.53	0.840	1215.3	4.77	82.9	1898

12 INCH WATER FILLED 316 STAINLESS STEEL MOTOR

Type	Pn [hp]	S.F	Un [Volts]	Thrust Load [N]	Full load Amps	RPM	Efficiency [%]	Cos φ [P.F]	TN [Nm]	Locked rotor Amps	[L] Length [in]	Gross weight [lbs.]
							F.L	F.L				
M12-1000-4604-316	100	1.15	460	70000	132.5	1760	87.49	0.812	407.1	4.50	51.4	800
M12-1000-5754-316	100	1.15	575	70000	104.9	1760	88.42	0.812	407.1	4.53	51.4	800
M12-1000-10004-316	100	1.15	1000	70000	59.4	1758	89.82	0.812	407.6	4.56	51.4	800
M12-1250-4604-316	125	1.15	460	70000	163.3	1760	87.87	0.818	504.8	4.55	54.1	923
M12-1250-5754-316	125	1.15	575	70000	129.0	1763	88.94	0.818	504.0	4.58	54.1	923
M12-1250-10004-316	125	1.15	1000	70000	73.2	1761	90.18	0.818	504.6	4.60	54.1	923
M12-1500-4604-316	150	1.15	460	70000	194.1	1762	88.33	0.820	596.4	4.57	57.3	1062
M12-1500-5754-316	150	1.15	575	70000	153.9	1762	89.11	0.820	596.4	4.62	57.3	1062
M12-1500-10004-316	150	1.15	1000	70000	87.1	1763	90.52	0.820	596.1	4.65	57.3	1062
M12-1750-4604-316	175	1.15	460	70000	227.2	1760	88.38	0.825	705.7	4.58	63.2	1243
M12-1750-5754-316	175	1.15	575	70000	180.1	1761	89.19	0.825	705.3	4.64	63.2	1243
M12-1750-10004-316	175	1.15	1000	70000	102	1762	90.53	0.825	704.9	4.67	63.2	1243
M12-2000-4604-316	200	1.15	460	70000	257.8	1760	87.99	0.830	814.3	4.60	67.1	1408
M12-2000-5754-316	200	1.15	575	70000	203.7	1763	89.07	0.830	812.9	4.64	67.1	1408
M12-2000-10004-316	200	1.15	1000	70000	115.5	1762	90.31	0.830	813.3	4.68	67.1	1408
M12-2250-4604-316	225	1.15	460	70000	288.3	1763	88.64	0.835	894.2	4.62	71.1	1457
M12-2250-5754-316	225	1.15	575	70000	228.5	1764	89.45	0.835	893.7	4.66	71.1	1457
M12-2250-10004-316	225	1.15	1000	70000	129.7	1763	90.64	0.835	894.2	4.70	71.1	1457
M12-2500-4604-316	250	1.15	460	70000	314.6	1760	88.30	0.845	1004.3	4.64	77.0	1686
M12-2500-5754-316	250	1.15	575	70000	248.3	1765	89.47	0.845	1001.4	4.67	77.0	1686
M12-2500-10004-316	250	1.15	1000	70000	141.4	1760	90.34	0.845	1004.3	4.71	77.0	1686
M12-2750-4604-316	270	1.15	460	70000	343.0	1761	88.78	0.845	1112.2	4.66	79.7	1792
M12-2750-5754-316	270	1.15	575	70000	271.3	1765	89.78	0.845	1109.7	4.69	79.7	1792
M12-2750-10004-316	270	1.15	1000	70000	154.7	1760	90.57	0.845	1112.8	4.72	79.7	1792
M12-3000-4604-316	300	1.15	460	70000	379.1	1762	88.68	0.840	1214.6	4.69	82.9	1914
M12-3000-5754-316	300	1.15	575	70000	300.1	1765	89.63	0.840	1212.5	4.73	82.9	1914
M12-3000-10004-316	300	1.15	1000	70000	170.8	1761	90.53	0.840	1215.3	4.77	82.9	1914

CABLE DATA

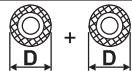
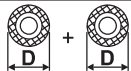
	12" WF STANDARD/12" WF 316SS	
HP	100 - 125	150 - 300
ph	3	3
Type of start	DOL	DOL
Cable x Leads x Size [AWG]	3 x 1 x 2 + 1 x 1 x 6	3 x 1 x 00 + 1 x 1 x 1
Length [ft]	16.4	16.4
D [inch]	0.55	0.55
		

12" WF STANDARD

12" WF 316SS

